

Service Maintenance Overview

Dynapac CC900G

Parts book

Service Kits & Lubricants

[CC900G \(Honda, Improved frame\) s/n 10000303xxA023833 - \(digabit.com\)](http://www.digabit.com)

Service Interval	Service Kit Part Number
50 Hour service kit	4700940463
200 Hour Service Kit	4812156486
500 Hour Service Kit	4812156487
1000 Hour Service Kit	4812156488
2000 Hour Service Kit	4812156488

Lubricant	Part Number	Qty	Qty	Qty	Qty	Qty
		required at 50 Hour Service	required at 200 Hour Service	required at 500 Hour Service	required at 1,000 Hour Service	required at 2,000 Hour Service
Dynapac Engine Oil 200 (5L)	4812161855	N/A	1	N/A	1	1
Dynapac Gear Oil 300 (5L)	4812161883	N/A	N/A	N/A	1	1
Dynapac Hydraulic 300 (20L)	4812161868	1	N/A	N/A	1	1

Service and maintenance points

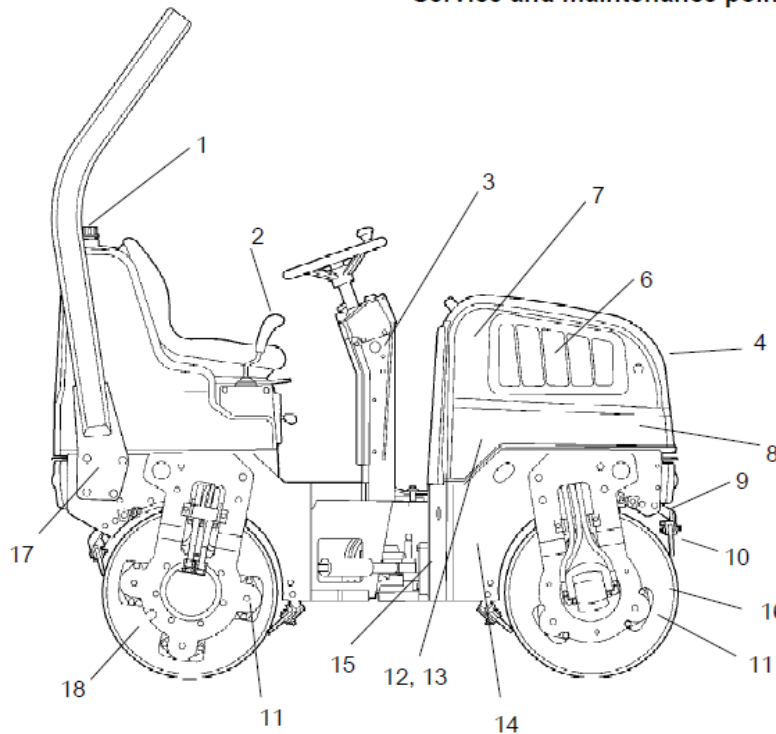

Fig. Service and maintenance points

- | | | |
|-------------------------------------|-------------------------------|--------------------------------------|
| 1. Water tank, filling | 7. Air cleaner | 13. Hydraulic fluid, filling |
| 2. Forward/Reverse lever | 8. Battery (maintenance free) | 14. Fuel tank, filling |
| 3. Reserve/parking brake | 9. Sprinkler | 15. Steering joint |
| 4. Hydraulic fluid cooler, (option) | 10. Scrapers | 16. Front drum, filling with oil |
| 5. Engine | 11. Rubber element | 17. ROPS, (option) |
| | 12. Hydraulic fluid filter | 18. Static drum, filling with water. |

Service Maintenance Overview



Dynapac CC900G

Repair Kits

900G		
4700945551	Shock absorber kit drum	4700945551 Shock absorber kit, drum (digabit.com)
4812314036	Scraper kit, from 002957	4812314036 Scraper kit, From 002957 (digabit.com)
4700945928	Repair kit, Steering hitch	4700945928 Repair kit, Steering hitch (digabit.com)
4700945710	Eccentric shaft kit	4700945710 Eccentric shaft kit (digabit.com)
4700945711	Drum rotation kit	4700945711 Drum rotation kit (digabit.com)
4812269909	Steele fuel tank kit	4812269909 Steel fuel tank kit (digabit.com)
4812280108	EPA field maintenance kit, from 008296	4812280108 EPA field maintenance kit, From 008296 (digabit.com)

General Comments

Inspected By: _____ **Signature:** _____

To be used as a reference only, always refer to the applicable Operators & Maintenance manual for confirm of correct service kits, lubricants and inspection tasks.



Service Checklist 10 Hours (Daily)



Dynapac CC900G

Machine Model: _____

Serial Number: _____

Hour Meter Reading: _____

Date of Inspection: _____

Required Service Kits & Lubricants

Nil Required Inspection Only

General Inspection Tasks

Task	OK	Not Ok	Comments
Check Light Functions, Work Lights, Beacon Light, etc.			
Check Function of Back Up Alarm			
Check Condition of Seat Belt and Mechanisms			
Check Function of Steering System			
Check Function of All Switches, Gauges and Indicators			
Check All Systems and Functions Operate as Per Operators Manual			
Check Evidence of Leaks in Systems			
Check Drum Scraper Position and Adjustment			
Check & Clean Free Circulation of Cooling Air			
Check Function of Brake System			
Check Drum Shock Absorbers and Bolts			
Check Sprinkler System Function			
Check Platform Mount Rubbers			
Check & Clean Battery Condition			
Check Level Engine Oil Top Up As Required			
Check Level Hydraulic Oil Top Up As Required			
Check Main Engine Air Filter Element			
Check Safety Engine Air Filter Element			

General Comments

Inspected By: _____

Signature: _____

To be used as a reference only, always refer to the applicable Operators & Maintenance manual for confirm of correct service kits, lubricants and inspection tasks.



Service Checklist First 50 Hours



Dynapac CC900G

Machine Model: _____

Serial Number: _____

Hour Meter Reading: _____

Date of Inspection: _____

Required Service Kits & Lubricants

Description	Part Number	Qty
50 Hour service kit	4700940463	1
Dynapac Hydraulic 300/20 ltrs	4812161868	1

General Inspection Tasks

Task	OK	Not Ok	Comments
Check Light Functions, Work Lights, Beacon Light, etc.			
Check Function of Back Up Alarm			
Check Condition of Seat Belt and Mechanisms			
Check Function of Steering System			
Check Function of All Switches, Gauges and Indicators			
Check All Systems and Functions Operate as Per Operators Manual			
Check Evidence of Leaks in Systems			
Check Drum Scraper Position and Adjustment			
Check & Clean Free Circulation of Cooling Air			
Check Function of Brake System			
Check Drum Shock Absorbers and Bolts			
Check Platform Mount Rubbers			
Check & Clean Battery Condition			
Check Level Hydraulic Oil			
Check Main Engine Air Filter Element			
Check Safety Engine Air Filter Element			

Maintenance Tasks

Task	Completed (mark with X)	Comments
Replace Engine Oil		
Replace Engine Oil Filter		
Replace Hydraulic Oil Filter		
Check & Grease Drum Bearing Seat		

General Comments

Completed By: _____

Signature: _____



Service Checklist First 50 Hours



To be used as a reference only, always refer to the applicable Operators & Maintenance manual for confirm of correct service kits, lubricants and inspection tasks.



Service Maintenance Overview



Dynapac CC900G

Machine Model: _____

Serial Number: _____

Hour Meter Reading: _____

Date of Inspection: _____

Required Service Kits & Lubricants

Description	Part Number	Qty
200 Hour Service Kit	4812156486	1
Dynapac Engine Oil 200 (5L)	4812161855	1

General Inspection Tasks

Task	OK	Not Ok	Comments
Check Light Functions, Work Lights, Beacon Light, etc.			
Check Function of Back Up Alarm			
Check Condition of Seat Belt and Mechanisms			
Check Function of Steering System			
Check Function of All Switches, Gauges and Indicators			
Check All Systems and Functions Operate as Per Operators Manual			
Check Evidence of Leaks in Systems			
Check Drum Scraper Position and Adjustment			
Check & Clean Free Circulation of Cooling Air			
Check Function of Brake System			
Check Sprinkler System Function			
Check Drum Shock Absorbers and Bolts			
Check Platform Mount Rubbers			
Check & Clean Battery Condition			
Check Level Hydraulic Oil Top Up As Required			
Check Main Engine Air Filter Element			
Check Safety Engine Air Filter Element			

Maintenance Tasks

Task	Completed (mark with X)	Comments
Replace Engine Oil		
Replace Engine Oil Filter		
Replace Fuel Filter		
Replace Spark Plugs		
Check Engine Idle Speed		
Check Engine Valve Clearances		
Grease Articulation Point and Steering		
Grease Controls and Joints		



Service Maintenance Overview



General Comments

Inspected By: _____

Signature: _____

To be used as a reference only, always refer to the applicable Operators & Maintenance manual for confirm of correct service kits, lubricants and inspection tasks.



Service Checklist 500 Hours



Dynapac CC900G

Machine Model: _____

Serial Number: _____

Hour Meter Reading: _____

Date of Inspection: _____

Required Service Kits & Lubricants

Description	Part Number	Qty
500 Hour Service Kit	4812156487	1

General Inspection Tasks

Task	OK	Not Ok	Comments
Check Light Functions, Work Lights, Beacon Light, etc.			
Check Function of Back Up Alarm			
Check Condition of Seat Belt and Mechanisms			
Check Function of Steering System			
Check Function of All Switches, Gauges and Indicators			
Check All Systems and Functions Operate as Per Operators Manual			
Check Evidence of Leaks in Systems			
Check Drum Scraper Position and Adjustment			
Check & Clean Free Circulation of Cooling Air			
Check Function of Brake System			
Check Drum Shock Absorbers and Bolts			
Check Sprinkler System Function			
Check Platform Mount Rubbers			
Check & Clean Battery Condition			
Check Level Hydraulic Oil Top Up As Required			
Check Level Drum Oil (Front) Top Up As Required			
Check Safety Engine Air Filter Element			
Check Breather Filter on Hydraulic Reservoir			

Maintenance Tasks

Task	Completed (mark with X)	Comments
Clean Engine Combustion Chamber		
Check Condition of Articulation Point		
Replace Air Filter Element		
Grease Controls and Joints		
Grease Articulation Point and Steering		



Service Checklist 500 Hours



General Comments

Inspected By: _____

Signature: _____

To be used as a reference only, always refer to the applicable Operators & Maintenance manual for confirm of correct service kits, lubricants and inspection tasks.



Service Checklist 1,000 Hours



Dynapac CC900G

Machine Model: _____

Serial Number: _____

Hour Meter Reading: _____

Date of Inspection: _____

Required Service Kits & Lubricants

Description	Part Number	Qty
1000 Hour Service Kit	4812156488	1
Dynapac Engine Oil 200 (5L)	4812161855	1
Dynapac Hydraulic 300/20 ltrs	4812161868	1
Dynapac gear oil 300/5 ltrs	4812161883	1

General Inspection Tasks

Task	OK	Not Ok	Comments
Check Light Functions, Work Lights, Beacon Light, etc.			
Check Function of Back Up Alarm			
Check Condition of Seat Belt and Mechanisms			
Check Function of Steering System			
Check Function of All Switches, Gauges and Indicators			
Check All Systems and Functions Operate as Per Operators Manual			
Check Evidence of Leaks in Systems			
Check Drum Scraper Position and Adjustment			
Check & Clean Free Circulation of Cooling Air			
Check Function of Brake System			
Check Drum Shock Absorbers and Bolts			
Check Sprinkler System Function			
Check Platform Mount Rubbers			
Check & Clean Battery Condition			
Check Level Hydraulic Oil Top Up As Required			
Check Level Drum Oil (Front & Rear) Top Up As Required			
Check Breather Filter on Hydraulic Reservoir			

Maintenance Tasks

Task	Completed (mark with X)	Comments
Replace Engine Oil		
Replace Engine Oil Filter		
Replace Hydraulic Oil Filter		
Replace Fuel Filter		
Replace Spark Plugs		
Check Engine Idle Speed		
Check Engine Valve Clearances		
Grease Articulation Point and Steering		



Service Checklist 1,000 Hours



Grease Controls and Joints		
Clean Engine Combustion Chamber		

Task Continued	Completed (mark with X)	Comments
Check Condition of Articulation Point		
Replace Air Filter Element		
Drain Condensate in Hydraulic Reservoir		
Drain Condensate in Fuel Tank		

General Comments

Inspected By: _____

Signature: _____

To be used as a reference only, always refer to the applicable Operators & Maintenance manual for confirmation of service kits, lubricants and inspection tasks.



Service Checklist 1,000 Hours



Service Checklist 1,000 Hours

--

of correct



Service Checklist 2,000 Hours



Dynapac CC900G

Machine Model: _____

Serial Number: _____

Hour Meter Reading: _____

Date of Inspection: _____

Required Service Kits & Lubricants

Description	Part Number	Qty
1000 Hour Service Kit	4812156488	1
Dynapac Engine Oil 200 (5L)	4812161855	1
Dynapac Gear Oil 300 (5L)	4812161883	1
Dynapac Hydraulic 300 (20L)	4812161868	1

General Inspections

Task	OK	Not Ok	Comments
Check Light Functions, Work Lights, Beacon Light, etc.			
Check Function of Back Up Alarm			
Check Condition of Seat Belt and Mechanisms			
Check Function of Steering System			
Check Function of All Switches, Gauges and Indicators			
Check All Systems and Functions Operate as Per Operators Manual			
Check Evidence of Leaks in Systems			
Check Drum Scraper Position and Adjustment			
Check Sprinkler System Function			
Check & Clean Free Circulation of Cooling Air			
Check Function of Brake System			
Check Drum Shock Absorbers and Bolts			
Check Platform Mount Rubbers			
Check & Clean Battery Condition			
Check Breather Filter on Hydraulic Reservoir			

2,000 Hour Service Checklist

Task	Completed (mark with X)	Comments
Replace Engine Oil		
Replace Engine Oil Filter		
Replace Hydraulic Oil Filter		
Replace Fuel Filter		
Replace Spark Plugs		
Check Engine Idle Speed		
Check Engine Valve Clearances		
Grease Articulation Point and Steering		
Grease Controls and Joints		
Clean Engine Combustion Chamber		



Service Checklist 2,000 Hours



Task Continued	Completed (mark with X)	Comments
Check Condition of Articulation Point		
Replace Air Filter Element		
Drain Condensate in Hydraulic Reservoir		
Drain Condensate in Fuel Tank		
Change Hydraulic Oil		
Change Drum Oil (Front Drum)		
Change Water in Rear Drum		

General Comments

Inspected By: _____

Signature: _____

To be used as a reference only, always refer to the applicable Operators & Maintenance manual for confirm of correct service kits, lubricants and inspection tasks.

