

## Dynapac CP274 Tier 4

Parts Book

### Service Kits & Lubricants

[CP274 s/n 10000507x0B002258 - 0B003863 - \(digabit.com\)](http://CP274_s/n_10000507x0B002258-0B003863-(digabit.com))

Service Interval	Service Kit Part Number (NO AOR)	Service Kit Part Number (WITH AOR)
Intital 50 Hour Service Kit	4812316684	4812316684
250/750 Hour Service Kit	4812316685	4812316686
500 Hour Service Kit	4812316687	4812316688
1000 Hour Service Kit	4812316689	4812316690
2000 Hour Service Kit	4812316689	4812316690

Lubricant	Part Number	Qty 50 Hour Service	Qty 250/500 Hour Service	Qty 1,000 Hour Service	Qty 2,000 Hour Service
Dynapac Engine Oil 200 (5L)	4812161855	3	3	3	3
Dynapac Gear Oil 300 (20L)	4812161884	1	N/A	1	1
Dynapac Coolant 100 (20L)	4812161854	N/A	N/A	N/A	1
Dynapac Hydraulic 300 (20L)	4812161868	N/A	N/A	N/A	6

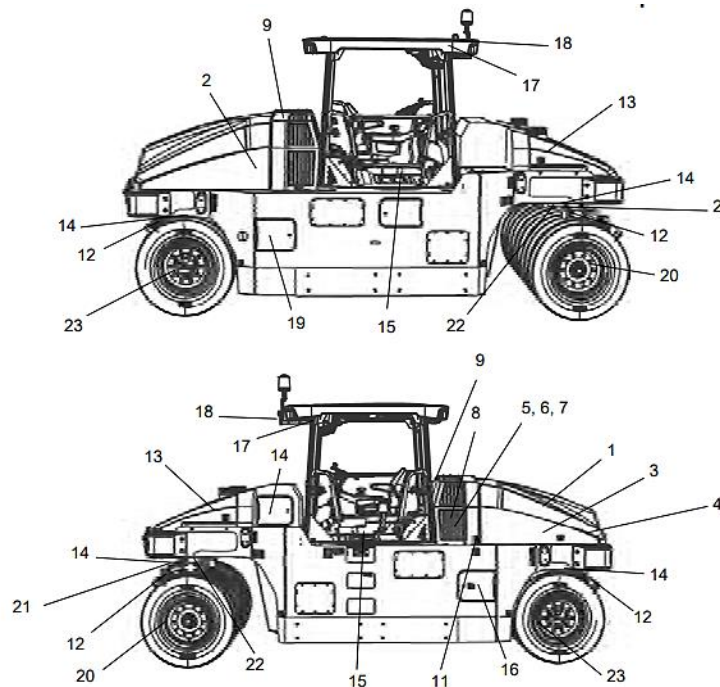

Fig. Service and maintenance points

- |                             |                           |                         |
|-----------------------------|---------------------------|-------------------------|
| 1. Engine oil               | 8. Hydraulic fluid cooler | 15. Seat bearing        |
| 2. Oil filter               | 9. Coolant                | 16. Battery             |
| 3. Fuel filter              | 10. Air cleaner           | 17. Cab, air filter     |
| 4. Hydraulic filter         | 11. Refueling             | 18. Cab, AC             |
| 5. Hydraulic fluid level    | 12. Scrapers              | 19. Edge cutter         |
| 6. Hydraulic fluid, filling | 13. Water tank, filling   | 20. Lower pivot bearing |
| 7. Hydraulic tank cap       | 14. Sprinkling system     | 21. Upper pivot bearing |
|                             |                           | 22. Pivot bearing       |
|                             |                           | 23. Wheel gear          |

# Service Maintenance Overview



# Repair Kit

## Dynapac CP274 Tier 4

### Repair Kits

<b>CP274</b>		
4812325419 + 4812325420	Scraper Kit + Cocoa Mat Kit	<a href="#">4812325419 4812325420 Scraper kit (digabit.com)</a>
4812155698	Sprinkler Kit	<a href="#">4812155698 Sprinkler kit (digabit.com)</a>
4812155752	AOR Kit Front	<a href="#">4812155752 AOR kit Front (digabit.com)</a>
4812155751	AOR Kit Rear	<a href="#">4812155751 AOR kit Rear (digabit.com)</a>

### General Comments

**Inspected By:** \_\_\_\_\_ **Signature:** \_\_\_\_\_

To be used as a reference only, always refer to the applicable Operators & Maintenance manual for confirm of correct service kits, lubricants and inspection tasks.



# Service Checklist 10 Hours (Daily)



## Dynapac CP274 Tier 4

Machine Model: \_\_\_\_\_

Serial Number: \_\_\_\_\_

Hour Meter Reading: \_\_\_\_\_

Date of Inspection: \_\_\_\_\_

### Required Service Kits & Lubricants

Nil Required Inspection Only

### General Inspection Tasks

Task	OK	Not Ok	Comments
Check Light Functions, Work Lights, Beacon Light, etc.			
Check Function of Window Wipers (if applicable)			
Check Function of Air Conditioner and Heater (if applicable)			
Check Function of Back Up Alarm			
Check Function and Locking of All Doors and Windows (if applicable)			
Check Condition of Seat Belt and Mechanisms			
Check Function of Steering System			
Check Function of All Switches, Gauges and Indicators			
Check All Systems and Functions Operate as Per Operators Manual			
Check Evidence of Leaks in Systems			
Check Scraper Position and Adjustment			
Check Sprinkler System Function			
Check & Clean Free Circulation of Cooling Air			
Check Function of Brake System			
Check Tyre Pressure			
Check Level Engine Oil			
Check Level Hydraulic Oil			
Check Level Coolant			
Check Main Engine Air Filter Element			
Check Safety Engine Air Filter Element			

### General Comments

Inspected By: \_\_\_\_\_

Signature: \_\_\_\_\_

To be used as a reference only, always refer to the applicable Operators & Maintenance manual for confirm of correct service kits, lubricants and inspection tasks.



# Service Checklist First 50 Hours



## Dynapac CP274 Tier 4

Machine Model: \_\_\_\_\_

Serial Number: \_\_\_\_\_

Hour Meter Reading: \_\_\_\_\_

Date of Inspection: \_\_\_\_\_

### Required Service Kits & Lubricants

Description	Part Number	Qty
Initial 50 Hour Service Kit	4812316684	1
Dynapac Engine Oil 200 (5L)	4812161855	3
Dynapac Gear Oil 300 (20L)	4812161884	1

### General Inspection Tasks

Task	OK	Not Ok	Comments
Check Light Functions, Work Lights, Beacon Light, etc.			
Check Function of Window Wipers (if applicable)			
Check Function of Air Conditioner and Heater (if applicable)			
Check Function of Back Up Alarm			
Check Function and Locking of All Doors and Windows (if applicable)			
Check Condition of Seat Belt and Mechanisms			
Check Function of Steering System			
Check Function of All Switches, Gauges and Indicators			
Check All Systems and Functions Operate as Per Operators Manual			
Check Evidence of Leaks in Systems			
Check Scraper Position and Adjustment			
Check Sprinkler System Function			
Check & Clean Free Circulation of Cooling Air			
Check Function of Brake System			
Check Tyre Pressure			
Check Wheel Nut Tension			
Check Cab Mount Rubbers			
Check & Clean Battery Condition			
Check Level Hydraulic Oil			
Check Level Coolant			
Check Main Engine Air Filter Element			
Check Safety Engine Air Filter Element			

### Maintenance Tasks

Task	Completed (mark with X)	Comments
Replace Engine Oil		
Replace Rear T Drive Gearbox (Left & Right)		
Replace Fuel Filter		
Replace Fuel Pre-Filter		
Replace Engine Oil Filter		



# Service Checklist First 50 Hours



Task Continued	Completed (mark with X)	Comments
Replace Hydraulic Oil Filter		
Replace Oil in Wheel Gear		
Grease Lower Pivot Bearings		
Grease Upper Pivot Bearing		

## General Comments

Completed By: \_\_\_\_\_

Signature: \_\_\_\_\_

To be used as a reference only, always refer to the applicable Operators & Maintenance manual for confirm of correct service kits, lubricants and inspection tasks.



# Service Checklist 250 Hours



## Dynapac CP274 Tier 4

Machine Model: \_\_\_\_\_

Serial Number: \_\_\_\_\_

Hour Meter Reading: \_\_\_\_\_

Date of Inspection: \_\_\_\_\_

### Required Service Kits & Lubricants

Description	Part Number	Qty
250/750 Hour Service Kit	4812316685 (No AOR)	1
	4812316686 (With	
Dynapac Engine Oil 200 (5L)	4812161855	3

### General Inspection Tasks

Task	OK	Not Ok	Comments
Check Light Functions, Work Lights, Beacon Light, etc.			
Check Function of Window Wipers (if applicable)			
Check Function of Air Conditioner and Heater (if applicable)			
Check Function of Back Up Alarm			
Check Function and Locking of All Doors and Windows (if			
Check Condition of Seat Belt and Mechanisms			
Check Function of Steering System			
Check Function of All Switches, Gauges and Indicators			
Check All Systems and Functions Operate as Per Operators Manual			
Check Evidence of Leaks in Systems			
Check Scraper Position and Adjustment			
Check Sprinkler System Function			
Check&Clean Free Circulation of Cooling Air			
Check Function of Brake System			
Check Tyre Pressure			
Check Wheel Nut Tension			
Check Cab Mount Rubbers			
Check&Clean Battery Condition			
Check Level Hydraulic Oil			
Check Level Coolant			
Check Main Engine Air Filter Element			
Check Safety Engine Air Filter Element			

### Maintenance Tasks

Task	Completed (mark with X)	Comments
Clean Hydraulic Oil Cooler/Water Cooler		
Grease Controls and Joints		
Grease Lower Pivot Bearings		



# Service Checklist 250 Hours



Task Continued	Completed (mark with X)	Comments
Grease Upper Pivot Bearing		
Check Cab Air Filter, Replace as Required (Optional)		

## General Comments

Inspected By: \_\_\_\_\_

Signature: \_\_\_\_\_

To be used as a reference only, always refer to the applicable Operators & Maintenance manual for confirm of correct service kits, lubricants and inspection tasks.





# Service Checklist 500 Hours



## Dynapac CP274 Tier 4

Machine Model: \_\_\_\_\_

Serial Number: \_\_\_\_\_

Hour Meter Reading: \_\_\_\_\_

Date of Inspection: \_\_\_\_\_

### Required Service Kits & Lubricants

Description	Part Number	Qty
500 Hour Service Kit	4812316687 (No AOR)	1
	4812316688 (With AOR)	
Dynapac Engine Oil 200 (5L)	4812161855	3

### General Inspection Tasks

Task	OK	Not Ok	Comments
Check Light Functions, Work Lights, Beacon Light, etc.			
Check Function of Window Wipers (if applicable)			
Check Function of Air Conditioner and Heater (if applicable)			
Check Function of Back Up Alarm			
Check Function and Locking of All Doors and Windows (if applicable)			
Check Condition of Seat Belt and Mechanisms			
Check Function of Steering System			
Check Function of All Switches, Gauges and Indicators			
Check All Systems and Functions Operate as Per Operators			
Check Evidence of Leaks in Systems			
Check Scraper Position and Adjustment			
Check Sprinkler System Function			
Check&Clean Free Circulation of Cooling Air			
Check Function of Brake System			
Check Tyre Pressure			
Check Wheel Nut Tension			
Check Cab Mount Rubbers			
Check&Clean Battery Condition			
Check Level Hydraulic Oil			
Check Level Coolant			
Check/Replace Main Engine Air Filter Element			
Check/Replace Safety Engine Air Filter Element			

### Maintenance Tasks

Task	Completed (mark with X)	Comments
Replace Engine Oil		
Replace Fuel Filter		
Replace Fuel Pre-Filter		
Replace Engine Oil Filter		
Grease Controls and Joints		



# Service Checklist 500 Hours



Task Continued	Completed (mark with X)	Comments
Grease Seat Bearing/Steering Chain		
Grease Lower Pivot Bearings		
Grease Upper Pivot Bearing		
Check Cab Air Filter, Replace as Required (Optional)		
Replace Air Dryer Filter (AOR ONLY)		

## General Comments

Inspected By: \_\_\_\_\_

Signature: \_\_\_\_\_

To be used as a reference only, always refer to the applicable Operators & Maintenance manual for confirm of correct service kits, lubricants and inspection tasks.



# Service Checklist 1,000 Hours



## Dynapac CP274 Tier 4

Machine Model: \_\_\_\_\_

Serial Number: \_\_\_\_\_

Hour Meter Reading: \_\_\_\_\_

Date of Inspection: \_\_\_\_\_

### Required Service Kits & Lubricants

Description	Part Number	Qty
1000 Hour Service Kit	4812316689 (No AOR)	1
	4812316690 (With AOR)	
Dynapac Engine Oil 200 (5L)	4812161855	3
Dynapac Gear Oil 300 (5L)	4812161884	1
Cabin Air Filter	4700395818	1

### General Inspection Tasks

Task	OK	Not Ok	Comments
Check Light Functions, Work Lights, Beacon Light, etc.			
Check Function of Window Wipers (if applicable)			
Check Function of Air Conditioner and Heater (if applicable)			
Check Function of Back Up Alarm			
Check Function and Locking of All Doors and Windows (if applicable)			
Check Condition of Seat Belt and Mechanisms			
Check Function of Steering System			
Check Function of All Switches, Gauges and Indicators			
Check All Systems and Functions Operate as Per Operators			
Check Evidence of Leaks in Systems			
Check Scraper Position and Adjustment			
Check Sprinkler System Function			
Check&Clean Free Circulation of Cooling Air			
Check Function of Brake System			
Check Tyre Pressure			
Check Wheel Nut Tension			
Check Cab Mount Rubbers			
Check&Clean Battery Condition			
Check Level Hydraulic Oil			
Check Level Coolant			
Check Oil Level Wheel Gear			

### Maintenance Tasks

Task	Completed (mark with X)	Comments
Replace Engine Oil		
Replace Rear T Drive Gearbox (Left & Right)		
Replace Fuel Filter		
Replace Fuel Pre-Filter		
Replace Engine Oil Filter		
Replace Hydraulic Oil Filter		
Replace Main Engine Air Filter Element		



# Service Checklist 1,000 Hours



Task Continued	Completed (mark with X)	Comments
Replace Safety Engine Air Filter Element		
Replace Breather Filter on Hydraulic Reservoir		
Grease Controls and Joints		
Grease Seat Bearing/Steering Chain		
Grease Lower Pivot Bearings		
Grease Upper Pivot Bearing		
Drain Condensate in Hydraulic Reservoir		
Drain Condensate in Fuel Tank		
Check Cab Air Filter, Replace as Required (Optional)		
Replace Air Dryer Filter		
Check Engine Drive Belt		
Check Engine Valve Clearance		

## General Comments

Inspected By: \_\_\_\_\_

Signature: \_\_\_\_\_

To be used as a reference only, always refer to the applicable Operators & Maintenance manual for confirm of correct service kits, lubricants and inspection tasks.



# Service Checklist 2,000 Hours



## Dynapac CP274 Tier 4

Machine Model: \_\_\_\_\_

Serial Number: \_\_\_\_\_

Hour Meter Reading: \_\_\_\_\_

Date of Inspection: \_\_\_\_\_

### Required Service Kits & Lubricants

Description	Part Number	Qty
2000 Hour Service Kit	4812316689 (No AOR)	1
	4812316690 (With AOR)	
Dynapac Engine Oil 200 (5L)	4812161855	3
Dynapac Gear Oil 300 (5L)	4812161884	1
Cabin Air Filter	4700395818	1
Dynapac Coolant 100 (20L)	4812161854	1
Dynapac Hydraulic 300 (20L)	4812161868	6

### General Inspections

Task	OK	Not Ok	Comments
Check Light Functions, Work Lights, Beacon Light, etc.			
Check Function of Window Wipers (if applicable)			
Check Function of Air Conditioner and Heater (if applicable)			
Check Function of Back Up Alarm			
Check Function and Locking of All Doors and Windows (if applicable)			
Check Condition of Seat Belt and Mechanisms			
Check Function of Steering System			
Check Function of All Switches, Gauges and Indicators			
Check All Systems and Functions Operate as Per Operators Manual			
Check Evidence of Leaks in Systems			
Check Scraper Position and Adjustment			
Check Sprinkler System Function			
Check & Clean Free Circulation of Cooling Air			
Check Function of Brake System			
Check Tyre Pressure			
Check Wheel Nut Tension			
Check Cab Mount Rubbers			
Check & Clean Battery Condition			

### Maintenance Tasks

Task	Completed (mark with X)	Comments
Replace Engine Oil		
Replace Hydraulic Oil		
Replace Coolant		
Replace Rear T Drive Gearbox (Left & Right)		
Replace Fuel Filter		
Replace Fuel Pre-Filter		



# Service Checklist 2,000 Hours



Task Continued	Completed (mark with X)	Comments
Replace Engine Oil Filter		
Replace Hydraulic Oil Filter		
Replace Main Engine Air Filter Element		
Replace Safety Engine Air Filter Element		
Replace Breather Filter on Hydraulic Reservoir		
Replace Oil in Wheel Gear		
Grease Controls and Joints		
Grease Seat Bearing/Steering Chain		
Grease Lower Pivot Bearings		
Grease Upper Pivot Bearing		
Drain Condensate in Hydraulic Reservoir		
Drain Condensate in Fuel Tank		
Drain&Clean Water Tank		
Clean Sprinkler System		
Check Cab Air Filter, Replace as Required		
Replace Air Dryer Filter (AOR ONLY)		
Check Engine Drive Belt		
Check Engine Valve Clearance		
Assess Overhaul Air Conditioning (Optional)		

## General Comments

Inspected By: \_\_\_\_\_

Signature: \_\_\_\_\_

To be used as a reference only, always refer to the applicable Operators & Maintenance manual for confirm of correct service kits, lubricants and inspection tasks.

