

Dynapac CT3000 Tier 4

Parts Book

[CT3000 Tier 4F s/n 10000513xxB005089 - \(digabit.com\)](http://digabit.com)

Service Kits & Lubricants

Service Interval	Service Kit Part Number (NO CAB)	Service Kit Part Number (WITH CAB)
Intital 50 Hour Service Kit	4812325006	4812325006
Intital 100 Hour Service Kit	Nil (Req Included in 50 Hour)	Nil (Req Included in 50 Hour)
250/750 Hour Service Kit	4812325007	4812325007
500 Hour Service Kit	4812325008	4812325009
1000 Hour Service Kit	4812325010	4812325011
2000 Hour Service Kit	4812325010	4812325011

Lubricant	Part Number	Qty required		Qty required		Qty required	
		at 50 Hour	at 100 Hour	at 250 & 500 Hour	at 1,000 Hour	at 2,000 Hour	
Dynapac Engine Oil 200 (5L)	4812161855	N/A	N/A	4	4	4	
Dynapac Gear Oil 300 (20L)	4812161884	N/A	5	N/A	5	1	
Dynapac Coolant 100 (20L)	4812161854	N/A	N/A	N/A	N/A	2	
Dynapac Hydraulic 300 (20L)	4812161868	N/A	N/A	N/A	N/A	12	
Transmission Oil (20L)	4000/2505C	N/A	N/A	N/A	2	2	
Transmission Oil (5L)	4000/2501C	N/A	N/A	N/A	1	1	

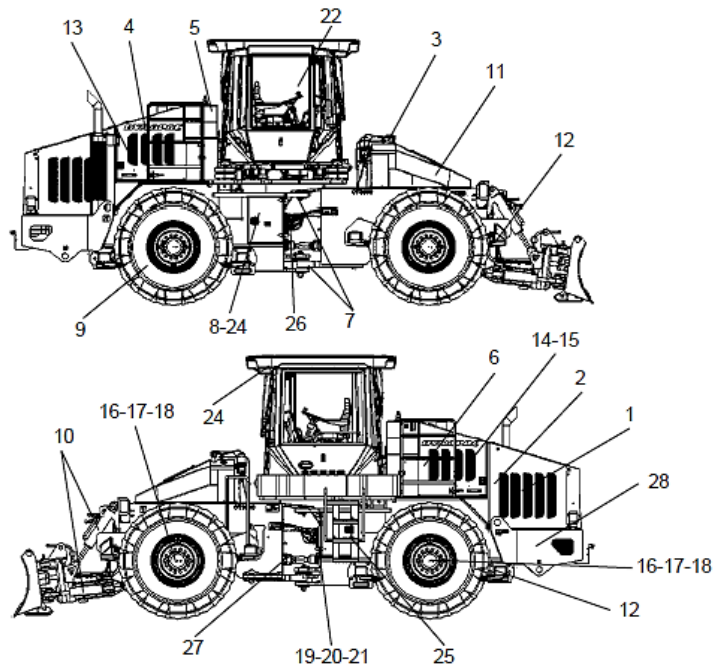

- | | | | |
|----------------------------|-------------------------------------|---------------------------------|---|
| 1. Radiator | 8. Batteries | 15. Engine oil filter | 22. Cab |
| 2. Alternator belt | 9. Tires | 16. Front and rear axle | 24. Fuse and relay box |
| 3. Pre-filter | 10. Hydraulic cylinder of the blade | 17. Wheel bolts | 25. Electronic modules |
| 4. Air filter | 11. Fuel tank | 18. Service brake | 26. Transmission box |
| 5. Hydraulic oil reservoir | 12. Scrapers | 19. Transmission box oil filter | 27. Longitudinal transmission shift |
| 6. Hydraulic oil filters | 13. Main fuel filter | 20. Transmission box oil | 28. Post-treatment of the exhaust gases (Engine IV) |
| 7. Chassis joint | 14. Engine lubricant oil | 21. Parking brake | |

Service Maintenance Overview



Repair Kit

Dynapac CT3000 Tier 4

Repair Kits

CT3000		
4812101738	Shock Absorber Kit	4812101738 Shock absorber kit (digabit.com)
4812101739	Shock Absorber Kit	4812101739 Shock absorber kit (digabit.com)

General Comments

Inspected By: _____ **Signature:** _____

To be used as a reference only, always refer to the applicable Operators & Maintenance manual for confirm of correct service kits, lubricants and inspection tasks.



Service Checklist 10 Hours (Daily)



Dynapac CT3000 Tier 4

Machine Model: _____

Serial Number: _____

Hour Meter Reading: _____

Date of Inspection: _____

Required Service Kits & Lubricants

Nil Required Inspection Only

General Inspection Tasks

Task	OK	Not Ok	Comments
Check Light Functions, Work Lights, Beacon Light, etc.			
Check Function of Window Wipers			
Check Function of Air Conditioner and Heater			
Check Function of Back Up Alarm			
Check Function and Locking of All Doors and Windows			
Check Condition of Seat Belt and Mechanisms			
Check Function of Steering System			
Check Function of All Switches, Gauges and Indicators			
Check All Systems and Functions Operate as Per Operators Manual			
Check Evidence of Leaks in Systems			
Check Drum Scraper Position and Adjustment			
Check&Clean Free Circulation of Cooling Air			
Check Function of Brake System			
Check & Align Cab Cushions			
Check&Clean Battery Condition			
Check Tyre Pressures			
Check Wheel Nut Tensions			
Check Engine Oil			
Check Level Hydraulic Oil			
Check Level Coolant			
Check Level Automatic Transmission Oil			
Check Main Engine Air Filter Element			
Check Safety Engine Air Filter Element			

General Comments

Inspected By: _____

Signature: _____



Service Checklist 10 Hours (Daily)



To be used as a reference only, always refer to the applicable Operators & Maintenance manual for confirm of correct service kits, lubricants and inspection tasks.



Service Checklist First 50 Hours



Dynapac CT3000 Tier 4

Machine Model: _____

Serial Number: _____

Hour Meter Reading: _____

Date of Inspection: _____

Required Service Kits & Lubricants

Description	Part Number	Qty
Initial 50 Hour Service Kit	4812325006	1
Nil Lubricants Needed		

General Inspection Tasks

Task	OK	Not Ok	Comments
Check Light Functions, Work Lights, Beacon Light, etc.			
Check Function of Window Wipers			
Check Function of Air Conditioner and Heater			
Check Function of Back Up Alarm			
Check Function and Locking of All Doors and Windows			
Check Condition of Seat Belt and Mechanisms			
Check Function of Steering System			
Check Function of All Switches, Gauges and Indicators			
Check All Systems and Functions Operate as Per Operators Manual			
Check Evidence of Leaks in Systems			
Check Drum Scraper Position and Adjustment			
Check & Clean Free Circulation of Cooling Air			
Check Function of Brake System			
Check & Align Cab Cushions			
Check & Clean Battery Condition			
Check Tyre Pressures			
Check Wheel Nut Tensions			
Check Engine Oil			
Check Level Hydraulic Oil			
Check Level Coolant			
Check Level Automatic Transmission Oil			
Check Main Engine Air Filter Element			
Check Safety Engine Air Filter Element			

Maintenance Tasks

Task	Completed (mark with X)	Comments
Replace Hydraulic Oil Filter		
Grease Chassis Joint Bearings		
Grease Steering System Bearings		
Grease Drive Axle Shafts		



Service Checklist First 50 Hours



General Comments

Completed By: _____

Signature: _____

To be used as a reference only, always refer to the applicable Operators & Maintenance manual for confirm of correct service kits, lubricants and inspection tasks.



Service Checklist First 100 Hours



Dynapac CT3000 Tier 4

Machine Model: _____

Serial Number: _____

Hour Meter Reading: _____

Date of Inspection: _____

Required Service Kits & Lubricants

Description	Part Number	Qty
Initial 100 Hour Service Kit	Nil (Req Included in 50 Hour)	0
Dynapac Gear Oil 300 (20L)	4812161884	5

General Inspection Tasks

Task	OK	Not Ok	Comments
Check Light Functions, Work Lights, Beacon Light, etc.			
Check Function of Window Wipers			
Check Function of Air Conditioner and Heater			
Check Function of Back Up Alarm			
Check Function and Locking of All Doors and Windows			
Check Condition of Seat Belt and Mechanisms			
Check Function of Steering System			
Check Function of All Switches, Gauges and Indicators			
Check All Systems and Functions Operate as Per Operators Manual			
Check Evidence of Leaks in Systems			
Check Drum Scraper Position and Adjustment			
Check&Clean Free Circulation of Cooling Air			
Check Function of Brake System			
Check & Align Cab Cushions			
Check&Clean Battery Condition			
Check Tyre Pressures			
Check Wheel Nut Tensions			
Check Engine Oil			
Check Level Hydraulic Oil			
Check Level Coolant			
Check Level Automatic Transmission Oil			
Check Main Engine Air Filter Element			
Check Safety Engine Air Filter Element			

Maintenance Tasks

Task	Completed (mark with X)	Comments
Replace Axle Oil (Front & Rear)		
Replace Transmission Oil Filter		
Grease Chassis Joint Bearings		
Grease Steering System Bearings		
Grease Drive Axle Shafts		



Service Checklist First 100 Hours



General Comments

Completed By: _____

Signature: _____

To be used as a reference only, always refer to the applicable Operators & Maintenance manual for confirm of correct service kits, lubricants and inspection tasks.



Service Maintenance Overview



Dynapac CT3000 Tier 4

Machine Model: _____

Serial Number: _____

Hour Meter Reading: _____

Date of Inspection: _____

Required Service Kits & Lubricants

Description	Part Number	Qty
250 Hour Service Kit	4812325007	1
Dynapac Engine Oil 200 (5L)	4812161855	4

General Inspection Tasks

Task	OK	Not Ok	Comments
Check Light Functions, Work Lights, Beacon Light, etc.			
Check Function of Window Wipers			
Check Function of Air Conditioner and Heater			
Check Function of Back Up Alarm			
Check Function and Locking of All Doors and Windows			
Check Condition of Seat Belt and Mechanisms			
Check Function of Steering System			
Check Function of All Switches, Gauges and Indicators			
Check All Systems and Functions Operate as Per Operators Manual			
Check Evidence of Leaks in Systems			
Check Drum Scraper Position and Adjustment			
Check&Clean Free Circulation of Cooling Air			
Check Function of Brake System			
Check Cab Cushions			
Check&Clean Battery Condition			
Check Tyre Pressures			
Check Wheel Nut Tensions			
Check Level Hydraulic Oil			
Check Level Coolant			
Check Level Automatic Transmission Oil			

Maintenance Tasks

Task	Completed (mark with x)	Comments
Replace Engine Oil		
Check Level Axle Oil (Front & Rear)		
Replace Fuel Filter		
Replace Fuel Pre-Filter		
Replace Engine Oil Filter		



Service Maintenance Overview



Task Continued	Completed (mark with X)	Comments
Grease Chassis Joint Bearings		
Grease Steering System Bearings		
Grease Drive Axle Shafts		

General Comments

Inspected By: _____

Signature: _____

To be used as a reference only, always refer to the applicable Operators & Maintenance manual for confirm of correct service kits, lubricants and inspection tasks.



Service Checklist 500 Hours



Dynapac CT3000 Tier 4

Machine Model: _____ Serial Number: _____

Hour Meter Reading: _____ Date of Inspection: _____

Required Service Kits & Lubricants

Description	Part Number	Qty
500 Hour Service Kit	4812325008 (NO Cab)	1
	4812325009 (WITH Cab)	
Dynapac Engine Oil 200 (5L)	4812161855	4

General Inspection Tasks

Task	OK	Not Ok	Comments
Check Light Functions, Work Lights, Beacon Light, etc.			
Check Function of Window Wipers			
Check Function of Air Conditioner and Heater			
Check Function of Back Up Alarm			
Check Function and Locking of All Doors and Windows			
Check Condition of Seat Belt and Mechanisms			
Check Function of Steering System			
Check Function of All Switches, Gauges and Indicators			
Check All Systems and Functions Operate as Per Operators Manual			
Check Evidence of Leaks in Systems			
Check Drum Scraper Position and Adjustment			
Check&Clean Free Circulation of Cooling Air			
Check Function of Brake System			
Check Cab Cushions			
Check&Clean Battery Condition			
Check Tyre Pressures			
Check Wheel Nut Tensions			
Check Level Hydraulic Oil			
Check Level Coolant			
Check Level Automatic Transmission Oil			

Maintenance Tasks

Task	Completed (mark with X)	Comments
Replace Engine Oil		
Check Level Axle Oil (Front & Rear)		
Replace Fuel Filter		
Replace Fuel Pre-Filter		
Replace Engine Oil Filter		
Replace Transmission Oil Filter		
Replace Main Engine Air Filter Element		



Service Checklist 500 Hours



Task Continued	Completed (mark with X)	Comments
Check Safety Engine Air Filter Element		
Check Breather Filter on Hydraulic Reservoir		
Grease Chassis Joint Bearings		
Grease Steering System Bearings		
Grease Drive Axle Shafts		
Grease Controls and Joints		
Grease Seat Bearing/Steering Chain		
Check Cab Air Filter, Replace as Required (Optional)		
Check Parking Brake Disc and Pads		
Check Wear of Service Brake Friction Disc		

General Comments

Inspected By: _____

Signature: _____

To be used as a reference only, always refer to the applicable Operators & Maintenance manual for confirm of correct service kits, lubricants and inspection tasks.



Service Checklist 1,000 Hours



Dynapac CT3000 Tier 4

Machine Model: _____

Serial Number: _____

Hour Meter Reading: _____

Date of Inspection: _____

Required Service Kits & Lubricants

Description	Part Number	Qty
	4812325010 (NO Cab)	
1000 Hour Service Kit	4812325011 (WITH Cab)	1
Dynapac Engine Oil 200 (5L)	4812161855	4
Dynapac Gear Oil 300 (20L)	4812161884	5
Dynapac Hydraulic 300 (20L)	4812161868	12
Transmission Oil (20L)	4000/2505C	2
Transmission Oil (5L)	4000/2501C	1

General Inspection Tasks

Task	OK	Not Ok	Comments
Check Light Functions, Work Lights, Beacon Light, etc.			
Check Function of Window Wipers			
Check Function of Air Conditioner and Heater			
Check Function of Back Up Alarm			
Check Function and Locking of All Doors and Windows			
Check Condition of Seat Belt and Mechanisms			
Check Function of Steering System			
Check Function of All Switches, Gauges and Indicators			
Check All Systems and Functions Operate as Per Operators Manual			
Check Evidence of Leaks in Systems			
Check Drum Scraper Position and Adjustment			
Check&Clean Free Circulation of Cooling Air			
Check Function of Brake System			
Check Cab Cushions			
Check&Clean Battery Condition			
Check Tyre Pressures			
Check Wheel Nut Tensions			
Check Level Hydraulic Oil			
Check Level Coolant			

Maintenance Tasks

Task	Completed (mark with X)	Comments
Replace Engine Oil		
Replace Automatic Transmission Oil		
Replace Axle Oil (Front & Rear)		
Replace Fuel Filter		
Replace Fuel Pre-Filter		



Service Checklist 1,000 Hours



Task Continued	Completed (mark with X)	Comments
Replace Engine Oil Filter		
Replace Hydraulic Oil Filter		
Replace Transmission Oil Filter		
Replace Main Engine Air Filter Element		
Replace Safety Engine Air Filter Element		
Check Breather Filter on Hydraulic Reservoir		
Grease Chassis Joint Bearings		
Grease Steering System Bearings		
Grease Drive Axle Shafts		
Grease Controls and Joints		
Grease Seat Bearing/Steering Chain		
Drain Condensate in Fuel Tank		
Check Cab Air Filter, Replace as Required (Optional)		
Check Engine Drive Belt		
Check Engine Valve Clearance		
Check Parking Brake Disc and Pads		
Check Wear of Service Brake Friction Disc		

General Comments

Inspected By: _____

Signature: _____

To be used as a reference only, always refer to the applicable Operators & Maintenance manual for confirm of correct service kits, lubricants and inspection tasks.



Service Checklist 2,000 Hours



Dynapac CT3000 Tier 4

Machine Model: _____

Serial Number: _____

Hour Meter Reading: _____

Date of Inspection: _____

Required Service Kits & Lubricants

Description	Part Number	Qty
2000 Hour Service Kit	4812325010 (NO Cab)	1
	4812325011 (WITH Cab)	
Dynapac Engine Oil 200 (5L)	4812161855	4
Dynapac Gear Oil 300 (20L)	4812161884	5
Dynapac Coolant 100 (20L)	4812161854	2
Dynapac Hydraulic 300 (20L)	4812161868	12
Transmission Oil (20L)	4000/2505C	2
Transmission Oil (5L)	4000/2501C	1

General Inspections

Task	OK	Not Ok	Comments
Check Light Functions, Work Lights, Beacon Light, etc.			
Check Function of Window Wipers			
Check Function of Air Conditioner and Heater			
Check Function of Back Up Alarm			
Check Function and Locking of All Doors and Windows			
Check Condition of Seat Belt and Mechanisms			
Check Function of Steering System			
Check Function of All Switches, Gauges and Indicators			
Check All Systems and Functions Operate as Per Operators Manual			
Check Evidence of Leaks in Systems			
Check Drum Scraper Position and Adjustment			
Check&Clean Free Circulation of Cooling Air			
Check Function of Brake System			
Check Cab Cushions			
Check&Clean Battery Condition			
Check Tyre Pressures			
Check Wheel Nut Tensions			

2,000 Hour Service Checklist

Task	Completed (mark with X)	Comments
Replace Engine Oil		
Replace Hydraulic Oil		
Replace Coolant		
Replace Automatic Transmission Oil		
Replace Axle Oil (Front & Rear)		



Service Checklist 2,000 Hours



Replace Fuel Filter		
Replace Fuel Pre-Filter		
Task Continued	Completed (mark with X)	Comments
Replace Engine Oil Filter		
Replace Hydraulic Oil Filter		
Replace Transmission Oil Filter		
Replace Main Engine Air Filter Element		
Replace Safety Engine Air Filter Element		
Replace Breather Filter on Hydraulic Reservoir		
Grease Chassis Joint Bearings		
Grease Steering System Bearings		
Grease Drive Axle Shafts		
Grease Controls and Joints		
Grease Seat Bearing/Steering Chain		
Drain&Clean Condensate in Hydraulic Reservoir		
Drain&Clean Condensate in Fuel Tank		
Check Cab Air Filter, Replace as Required (Optional)		
Check Engine Drive Belt		
Check Engine Valve Clearance		
Check Engine Crankshaft Shock Absorber		
Check Parking Brake Disc and Pads		
Check Wear of Service Brake Friction Disc		
Assess Overhaul Air Conditioning (Optional)		

General Comments

Inspected By: _____

Signature: _____

To be used as a reference only, always refer to the applicable Operators & Maintenance manual for confirm of correct service kits, lubricants and inspection tasks.

